



## HTB Series, High Temperature Circular Connectors

With over 60 years of experience in interconnect solutions in the rail market, ITT Veam understands the critical role connectors play in rail safety.

### The challenge

To help insure rail passengers can safely evacuate a train during the event of a fire, the European Rail Agency (ERA) developed specific requirements (TSI - Technical Specifications for Interoperability) for safety in Railway Tunnels.

Since connectors are a primary sources of power distribution, connectors for critical control signals must work and be resistant for 15 minutes, if exposed to the ISO 834-1 heating curve (at 738°C).

### The solution

Up for the challenge, the ITT Veam team took the reliable design of the Veam CIR series and modified the material and specifications to meet the fire code standards.

During testing, the high temperature HTB connector was successfully able to withstand 800°C (ISO 834-1 heating curve) for nearly 30 minutes while maintaining critical control signals.

### The Veam difference

- Quick connect and discount
- Tested at 800°C for 30 minutes

### Applications

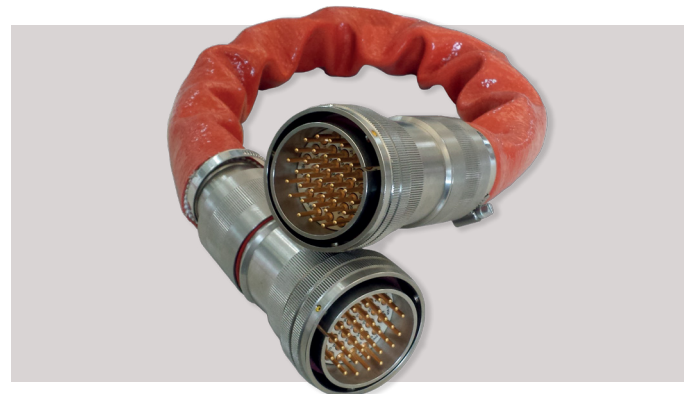

### Key feature

- Shells: stainless steel
- Insulators: ceramic
- Grommet: Flame retardant rubber
- Contacts: with metallic retention clip
- Arrangements:
  - 40A - 35 (35 poles size 12, crimp type)
  - Operating voltage: DC700V, AC500V
  - Rated current 23A



1- CONVERTERS

2- TRACTION MOTORS

3- INTER-VEHICLES

4- POWER DISTRIBUTION

## HTB Series, High Temperature Connector Specifications

Material and Plating			
Shells	Stainless steel (AISI 303 passivated)		
Insulator	Ceramic material		
Grommet	"FLAME RETARDANT" rubber		
Gaskets	Silicone rubber		
Contacts	Copper alloy, gold plated		
Contacts type	N • 35 contacts size "12". crimp type		
Applicable cables	Stranded wire with section up to 2.5 sqmm / AWG12*		
Mechanical/Environmental Characteristics			
Operating temperature	-55°C to 180°C	Protection degree in mated conditions	IP67 (EN60529) in mated condition with proper accessories
Mating cycles	Up to 500	Corrosion resistance	>500 hrs salt spray
Vibrations	20g from 10 to 2000Hz	Contacts retention	Size 12 - 100 N acc. to NFF 61-030 reinforced up to 150N
Electrical Characteristics			
Operating voltage	500 Vac / 700 Vdc	Rated current	23 Amps at 20°C
Test voltage	2000 Vac	Max. contact current	41 Amps at 20°C
Insulation resistance	5000MOhm Min.		
Other Characteristics	According to VG95234 specifications where applicable. Fire resistant heating curve ISO834-1 for 15 minutes.		

\* Consult factory for more details

## Outline Drawings for Receptacle and Plugs

Receptacle with grommet

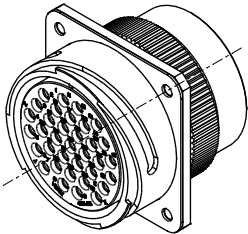

Plug with grommet and adapter for rubber tube

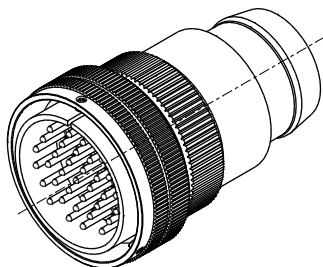

Plug with grommet, internal cable clamp and adapter for rubber tube

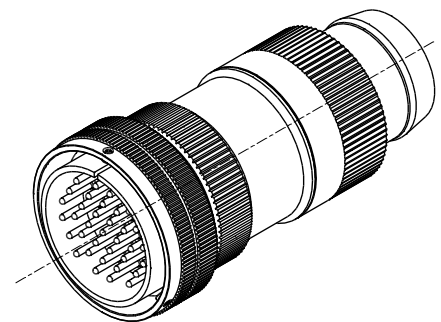

## Why ITT

ITT is a focused multi-industrial company that designs and manufactures highly engineered critical components and customized technology solutions.

ITT's Veam brand is a leading global manufacturer of connector products serving international customers in transportation end markets. ITT's Connector business, which also includes the Cannon and BIW Connector Systems brands, manufactures and supplies a variety of connectors and interconnects that make it possible to transfer data, signal and power in an increasingly connected world.

Connect with your ITT Veam representative today or visit us at [www.ittcannon.com](http://www.ittcannon.com)

### North America

56 Technology Drive  
Irvine, CA 92618  
Phone: +1.800.854.3028

### Europe

Italy  
Corso Europa 41/43  
20020 Lainate (MI) Italy  
Phone: +39.02938721

### Asia

Tuopandun Industrial Area, Jinda Cheng,  
Xiner Village, Shajing Town, Boan District,  
Shenzhen City, Guangdong Province, China 518215  
Phone: +86.755.2726.7888